

MINI POWER RAKE

FOR COMPACT UTILITY LOADERS

THE DIGGA MINI POWER RAKE GRADES, LEVELS, RAKES, AND REMOVES DEBRIS, PULVERIZING AND PREPARING THE GROUND FOR NEW SEEDBED, TURF OR TO REMOVE OLD LAWN AND WEEDS - ALL WITH ONE TOOL. OUR POWER RAKE FOR COMPACT UTILITY LOADERS, SMALL SKID STEER LOADERS AND SMALL ARTICULATED LOADERS IS IDEAL FOR GOLF COURSES, WINERIES, PAVING, AND A GREAT TOOL FOR CONTRACTORS.

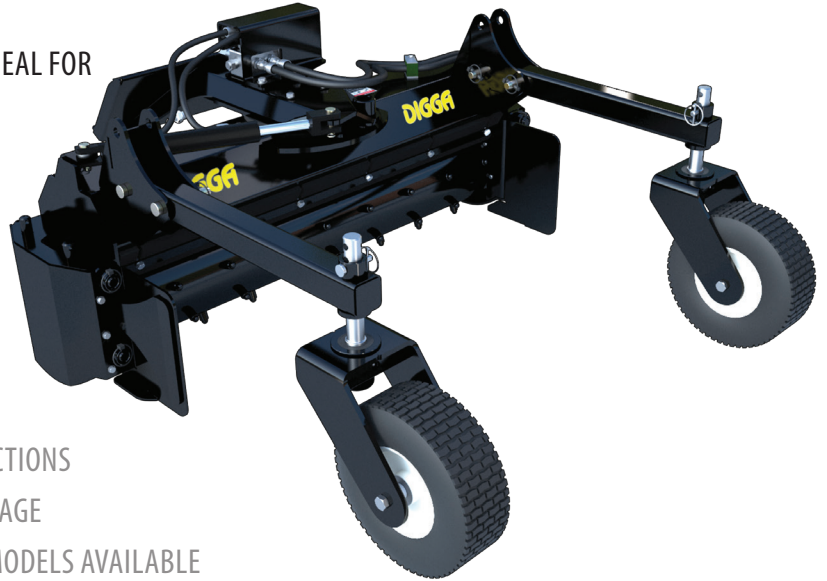

FEATURES

- FULLY HYDRAULIC 48" & 60" DRUM WIDTH
- REMOVABLE SPOIL PLATES FOR WINDROWING
- HYDRAULIC ANGLING UP TO 20 DEGREES LEFT & RIGHT
- BI-DIRECTIONAL DRUM CAN WORK SOIL IN BOTH DIRECTIONS
- REMOVABLE WHEELS FOR EASY TRANSPORT AND STORAGE
- MANUAL, HYDRAULIC & ELECTRIC/HYDRAULIC SLEW MODELS AVAILABLE
- MADE IN THE USA

SPECIFICATIONS	48"	60"
RECOMMENDED FLOW RANGE	9 - 20 GPM	
MOTOR	2K BELL EATON	
MAXIMUM PRESSURE - DO NOT EXCEED	3500 PSI @ 16 GPM	
MAXIMUM FLOW - DO NOT EXCEED	30 GPM @ 1800 PSI	
MAXIMUM POWER - DO NOT EXCEED	25 KW (34 HP)	
DRUM WIDTH	48"	60"
OVERALL WIDTH	58"	70"
LENGTH - WHEELS DOWN	55"	55"
LENGTH - NO WHEELS	31"	31"
WEIGHT (Varies depending on mount)	599-743 LBS	616 - 760LBS



IDEAL USE

LEVELLING, GRADING, SEEDBED PREPARATION, SITE PREPARATION, LAWN CARE, GOLF COURSES, WINERIES, PAVING, CONTRACTORS

MACHINE SUITABILITY

COMPACT UTILITY & SMALL ARTICULATED LOADERS